

# ARCHERY STUDY GUIDE

Name \_\_\_\_\_

Period \_\_\_\_\_ Date \_\_\_\_\_

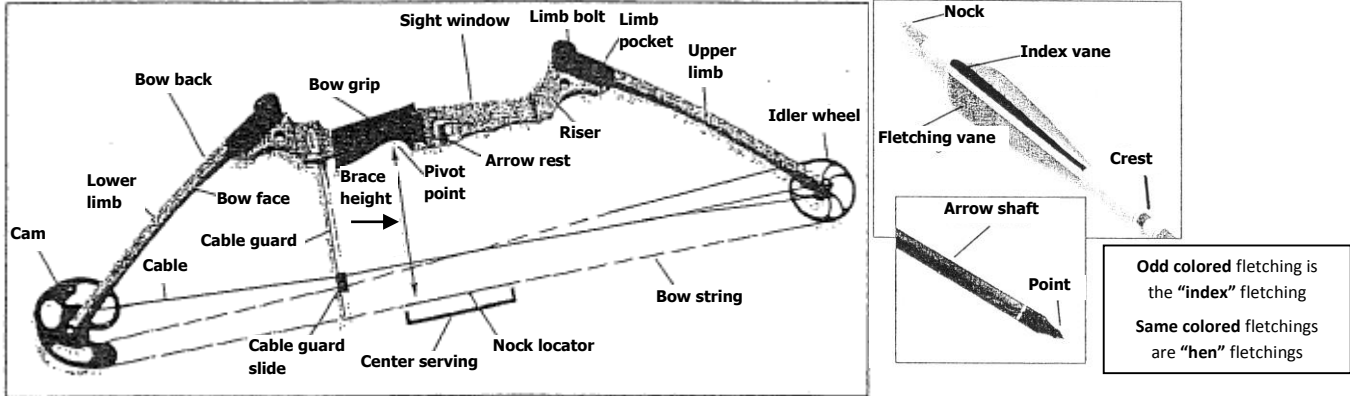

## SAFETY PRECAUTIONS/SPORTSMANSHIP

Bows and arrows are potentially dangerous. However, when safety procedures and precautions are followed, it is an enjoyable and safe activity. Listed below are important rules that will help make it a safe activity for everyone in class.

1. Never point a loaded bow at anyone.
2. Arrows should be nocked while pointing at the archery target.
3. Everyone must follow the instructor's shooting commands.
4. Stay behind the shooting line until the signal to retrieve your arrows is given by the instructor.
5. Never draw an arrow beyond the arrow rest. If the arrow is too short for the bow, the individual should request a replacement.
6. When not shooting, stand back away from the shooting line. Do not distract someone shooting.
7. Check for and replace broken or damaged equipment.
8. Do not "dry fire" the bow. This means drawing and releasing the string without an arrow. This may cause damage to the bow.
9. If you see a student in danger, yell, "stop shooting."

## SHOOTING PROCEDURES AND COMMANDS

**WAITING LINE:** This is the line behind the shooting line for those students waiting their turn to shoot.

**SHOOTING AND RETRIEVING:** These are the commands the instructor will give those at the shooting line.

1. **"Address the target":** Shoot and straddle the line and place the bow parallel to the floor.
2. **"Nock your arrow"** Properly remove the arrow from the cone and correctly nock it on the bow serving.
3. **"Draw and aim"** Draw the string to the anchor and take aim.
4. **"Release"** Relax your draw fingers and back of your draw hand all at once. Draw hand should end up by your shoulder.
5. **"Continue shooting"** Using steps 1-4 continue shooting the remaining arrows. When finished, place your bow on the cart and wait for the retrieval signal.
6. **"Retrieve arrows"** Two hands must always be used when removing an arrow. Place the palm of your non-dominant hand flat against the target face with the arrow between your thumb and index finger. The dominant hand should be touching the flat hand and be wrapped around the shaft of the arrow. Pull the arrow out of the target at the same angle as it went into the target. Set each arrow down as you remove the next arrow from the target. Walk back to the shooting line with your arrow fletchings separated and one hand over the points of the arrows.

## SCORING

**Colored facings: Yellow = 9 pts, Red = 7 pts, Blue = 5 pts, Black = 3 pts, White = 1 pt**

An arrow that splits two colors receives the higher value.

An arrow that hits the scoring face and bounces off is worth 0 points.

An arrow in the petticoat or one that misses the target completely receives 0 points.

## SCORE SHEET

Always mark the arrows from highest to lowest. Example: 9 – 3 – 1

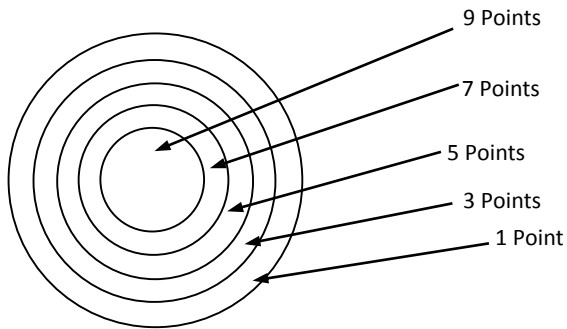

	Round	End 1	End 2	End 3	TOTAL
<b>Correct</b>	<b>1</b>	<b>9</b>	<b>5</b>	<b>3</b>	<b>17</b>
<b>Incorrect</b>	<b>2</b>	<b>3</b>	<b>9</b>	<b>5</b>	<b>17</b>
<b>Correct</b>	<b>3</b>	<b>7</b>	<b>5</b>	<b>1</b>	<b>13</b>
<b>Incorrect</b>	<b>4</b>	<b>7</b>	<b>1</b>	<b>5</b>	<b>13</b>
<b>Correct</b>	<b>5</b>	<b>5</b>	<b>3</b>	<b>0</b>	<b>8</b>
<b>Incorrect</b>	<b>6</b>	<b>0</b>	<b>3</b>	<b>5</b>	<b>8</b>

## TERMS

- Anchor Point** – touching your index finger to the corner of your mouth with the bow at full draw.
- Bow Arm** – the arm that the archer prefers to use for holding the bow during shooting.
- Index Fletching** – this fletching is a different color than the other two fletchings.
- Compound Bow** – A bow that uses a system of cams, pulleys, and cables to gain additional mechanical advantage.
- Creeping** – an undesired forward motion of the bowstring from the anchor point immediately prior to release.
- Crest** – colored marks on the arrow used for identification.
- Draw** – the pulling back of the bowstring; also, the distance to which the bow is drawn.
- End** – a designated number of arrows shot in succession before retrieving.
- Fletching** – the feathers or vanes attached to an arrow between the nock and crest.
- Free Style** – competitive shooting using a bow sight.
- Grouping** – the arrangement of arrows in the target close to each other.
- Hen Fletchings** – the two fletchings that are similar in color.
- Hit** – to strike the target on its scoring surface.
- Instinctive Shooting** – aiming and shooting a bow without the aid of a bow sight. Also called bare bow method.
- Nock** – the plastic device on the end of the arrow opposite the point to place on the string; a groove at the end of the bow for the string placement; and the act of placing the arrow on the string – “nocking the arrow”.
- Nock Locator** – arrow nock is placed below it on the serving.
- Petticoat** – the edge of the target face beyond the widest or white ring.
- Point of Aim** – a spot on the ground, target, or background at which the archer aims; it should be directly on the arrow tip when the arrow is released.
- Point Blank Range** – the distance at which the point of aim is the center of the target.
- Range** – the shooting distance.
- Recurve Bow** – a bow with tips that curve back in a graceful arch.
- Round** – shooting a prescribed number of ends at a specific distance.
- Serving** – the protective thread wrapped around the bowstring where the arrow is nocked.
- Shaft** – the main part of the arrow.
- Shooting Line** – the line that marks a specific distance on the range. Archers straddle this line while shooting.
- Scattered** – arrows distributed unevenly over a large portion of the target face and/or ground.
- Trajectory** – the path or arch of the arrow in flight.